

LINEAR MOTOR MG-256

TECHNICAL DESCRIPTION:

These devices are, in fact, electric servomotors, intended for linear direct drive of machine elements and technological lines, where high speeds of movement, dynamics, precision and frequent or dynamic reconfiguration of the movement trajectory (on-line) are required. In such situations, the linear motor is an excellent alternative to pneumatic actuators or electric drives with ball screw or drive belt. The motor is characterized by high reliability and low wear during operation. It does not require special lubrication or seals. The involvement of maintenance services is much lower compared to other types of linear drive. No need to connect compressed air makes it much easier to maintain the cleanliness regime in cleanrooms.

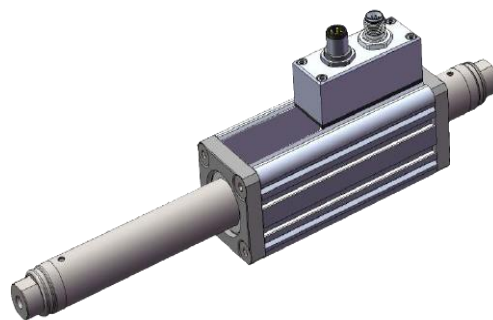

The motor consists of two main elements: the forcer with windings and position sensor and the sliding shaft filled with permanent magnets, which works concentrically with the forcer. The working load can be attached to the moving shaft (the forcer is permanently attached to the machine body) or to the forcer (the shaft is stationary and the forcer moves).

A non-contact linear encoder is built in the motor, which provides a feedback signal for control systems in the sin/cos 1Vpp standard and thermal overheating protection.

To supply and control the motor, a properly configured servo amplifier is required, which accepts the kind of the feedback signal and ensures that the parameters required by the motor are achieved. The servo amplifier can come from any manufacturer, as long as it meets the requirements of the motor.

PARAMETERS:	
Positioning accuracy:	±350 μm
Positioning repeatability:	±20 μm
Shaft diameter:	25 mm
Operational temperature:	-20°C ÷ +40°C
*Continuous force:	no less than 22,7 N
*Peak force:	170 N
* Maximum velocity:	4,0 m/s
* Maximum acceleration:	200 m/s ²
* Min. working length:	60 mm and more
* Min. shaft length:	235 mm

EXAMPLE APPLICATIONS:

- packaging machines,
- dosing machines,
- pick & place systems,
- automatic assembly,
- feeders and manipulators,

* Parameters marked with an asterisk are indicative and the motor may be designed with other parameters according to customer requirements.